



Made in Korea

DRILLING SPECIALIST

Leading Manufacturer of D.T.H. Equipment
Total Solution Provider

CS Drilling Rig Series

CS Hammer Series

CS Button Bit Series

CS Auxiliary Equipment

CSI
www.okcsi.com



Chang Shin International Co., Ltd.



CHANG SHIN International

Leading Manufacturer of D.T.H. Equipment Specialized in Customizing Service
Total Solution Provider

Chang Shin International is a well-known manufacturer of high quality drilling equipment in Korea. Since 1993, we have manufactured various drilling equipment such as drilling rigs, hammers, bits, and most of auxiliary drilling equipment for your successful business. Customers from more than 40 countries around the world have guaranteed the quality of our wide ranges of drilling products.

CSI hold several patents and certifications that certify its excellence and credibility in the field. And we sincerely promise a high-quality product that never compromises with anything. CSI are now here for your successful business with cutting-edge technology and plentiful experience for sharing the benefits together.

Exporting To Over 50 Countries Around The World





Company History

Foundation 1993~2002

- 1993 Established Chang Shin International
- 1996 Start Export to USA, Europe, etc
- 2002 Complete Ulsan Factory

Growth 2003~2010

- 2004 Develop Advanced Roof Piling M/C
Obtain Patent on Drill & Insert Comb M/C
Acquire ISO 9001 Certification
Acquire CE Mark for CS Power Hammer
- 2005 Acquire CE Mark for Drilling Rig
- 2006 Appointed as Management Innovation Co.
- 2007 Win Korea Presidential Award for 1M Export
Obtain Patent on Auger Hammer
- 2010 Acquire Inno-Biz Certification

Advancement 2011~

- 2011 Establish R & D Center
Acquire ISO 14001 Certification
- 2012 Appointed as Global Power Company
Acquire Venture Company Certification
- 2013 Appointed as Global Brand Company
Appointed as Global Star Venture Company
Win Presidential Award for 3M Export
- 2014 Appointed as IP Star Company
Expand Company in Ulsan Free Trade Zone
- 2015 Obtain Patent on Speedrill & Mud Pump
- 2016 Develop Water Hammer & Mud Pump
- 2017 Develop Water Cluster Hammer
(First for the 2017 world)
- 2018 Develop KR-5000 Drilling Machine

World Best Quality & Most Reasonable Price

Certificates

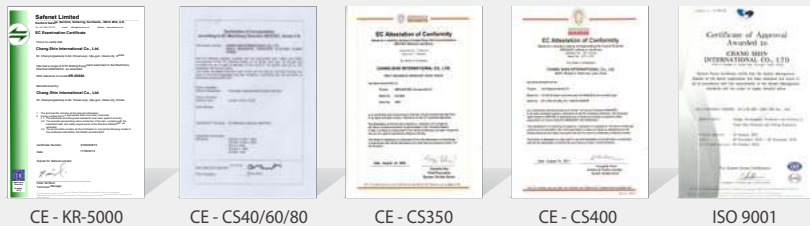

CE - KR-5000 CE - CS40/60/80 CE - CS350 CE - CS400 ISO 9001



ISO 14001 Export Firm R & D Center INNO-BIZ Venture Firm KOSHA 18001

Patents



Mud Hammer Hydraulic Clamp Drilling & Piling Auger Hammer Water Hammer Control Valve



W. Hammer Part Nozzle Air Distri. Cluster Hammer Wave Generator Rod Handler Fan Generator Mud Pump

CS Hammer Series

Advanced Design
Adopt Air-Regulating Distributor
Easy to Replace Bits and Hammers

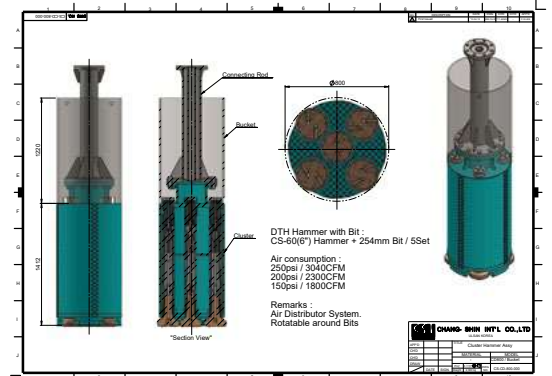

CS Cluster Hammer/ Bucket

CS cluster hammer consists of Bucket and RC types, which ensure high efficiency and durability. It is now recognized as a new standard for big-size drilling.



	Model	CD 1000	CD1180	CD1350
CS Cluster Hammer Spec / Bucket Type	Length	2,800mm	3,853mm	4,068mm
	Out dia.	1,000mm	1,180mm	1,350mm
	Weight	Estimate 3,500kg	Estimate 4,500kg	Estimate 5,700kg
	Air consumption	150psi / 2,030cfm	150psi / 2,580cfm	150psi / 3,120cfm
		200psi / 2,500cfm	200psi / 3,000cfm	200psi / 3,680cfm
		250psi / 3,260cfm	250psi / 3,850cfm	250psi / 4,860cfm
	Pull down	1,800 ~ 5,800kgf	2,800 ~ 6,800kgf	4,000 ~ 8,000kgf
	Rotation speed	4-5rpm	4-5rpm	3-4rpm
Composition	CS-NEO-60-Hammer + 225mm Bit / 6 SET	CS-NEO-60-Hammer + 225mm Bit / 7 SET	CS-NEO-60-Hammer + 225mm Bit / 8 SET	

CS Cluster Hammer/ RC

Adopt Air-Regulating Distributor

- Individual bit free rotating/ Operable in any ground condition(cleft or steep slope)

Adopt Replaceable RC Pipe

- Save cost & time for maintenance

Flushing Volume Control

- Increase working performance & safety



*Best Solution for
Big-Size Piling*



CS Cluster Hammer Spec / RC Type	Model	RC Cluster OD1200	RC Cluster OD2000	RC Cluster OD2500
	Length	2,836mm	2,836mm	2,836mm
	Out dia.	1,200mm	2,000mm	2,500mm
	Weight	Estimate 5,000kg	Estimate 12,600kg	Estimate 16,400kg
	Air consumption	150psi / 2,730cfm	150psi / 5,700cfm	150psi / 8,970cfm
		200psi / 3,220cfm	200psi / 6,750cfm	200psi / 10,580cfm
		250psi / 4,260cfm	250psi / 8,170cfm	250psi / 14,030cfm
	Pull down	3,325 ~ 6,500kgf	7,125 ~ 17,600kgf	10,925 ~ 21,400kgf
	Rotation speed	4-5rpm	2-3rpm	2-3rpm
Composition	CS-NEO-60-Hammer + 225mm Bit / 7 SET	CS-NEO-60-Hammer + 225mm Bit / 15 SET	CS-NEO-60-Hammer + 225mm Bit / 23 SET	

CS Water Hammer



Operated by High-Pressure Water
Save Energy & Resources
Reduce Air/ Soil/ Noise Pollution

CS Water Hammer

CSI's water hammer is operated by high-pressure water from a water pump instead of high-pressure air from many compressors. So, it can save energy and other resources dramatically.

And, CSI's water hammer is designed to protect environment by using water from recycling system. It also doesn't need lubrication oil for hammering, so there is nothing to worry about water & soil pollution because of oil sludge.

WAROC Series Specifications

	WAROC 75	WAROC 100	WAROC 125	WAROC 150	WAROC 200
Length (mm)	1,083	1,135	1,284	1,350	1,625
Diameter (mm)	Φ 92	Φ 111 - 123	Φ126 - 136	Φ160 - 198	Φ210 - Φ248
Wrench Size (mm)	64	69	100	99	140
Weight (kg)	37.6	55	103	175	226
Bit Diameter (mm)	Φ 95	Φ 115 - 127	Φ130 - 140	165 - 203	Φ216 - Φ254
Max Operating Pressure (bar)	180	180	180	150	150
Water Consumption (l/min)	100 - 280	150 - 360	220 - 470	240 - 520	300 - 680
Feed Force (kgf) * Formation Dependant	700 - 900	800 - 1,500	1200 - 2300	1500 - 3000	3000
Rotation Speed (rpm) * Formation Dependant	60 - 100	50 - 90	50 - 80	40 - 65	25 - 50
Rotation Torque (Nm) * Formation Dependant	800 - 1500	1,000 - 2,000	1500 - 3000	2000 - 4000	3000 - 5000
Drill Pipe (mm)	Φ 76	Φ 89	Φ 114	Φ 114 / Φ 140	Φ 168 / Φ 194
Bit Shank	DHD3.5	DHD340	DHD350	DHD360	DHD380

Water Recycling System

Save Energy System

Decrease Air/ Soil/ Noise Pollution System



Water Collector



Drilling Rig



Water Cluster Hammer

CSI has developed water cluster hammer. It combines all benefits of RCD drilling and water hammer drilling methods. It can reduce environmental issues and increase working speed extremely.

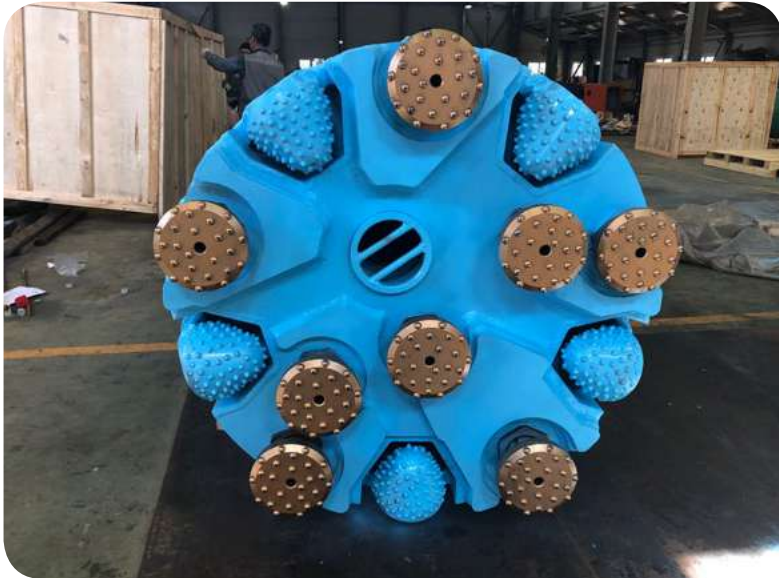

Water Pump

Low Maintenance Cost
Easy to Transfer & Install
User Friendly & High Safety
High Efficiency & Long Lifespan



Wall Stability
Fast Drilling Speed
Low Fuel Consumption



Dimension & Weight		
Width	1.4	M
Height	1.64	M
Length	3	M
Weight(Dry)	1	Ton

Engine	
Model	DOOSAN(PU086)
Power	113KW / 1800rpm

Specification	
Input	1500rpm
Flow Rate(L/Min)	333 Litter/ Min
Max.Pressure(Bar)	175 Bar

CS KR-5000



New Model – KR-5000

Eco-Friendly

Improved Structural Stability

Field Requirements-Satisfied

KR-5000 Specifications (Standard)

Item		Unit	Specifications
Weight (Including rod)		Kg	46,800
Engine	Brand/Model	—	Cummins Engine QSB 6.7
	Fuel type/Cylinder	—	Diesel/Six-cylinder
	Rated power	ps/rpm	252.8/2000
	Maximum torque	kgf.m/rpm	98.9/1,500
	Fuel tank capacity	ℓ	500
Hydraulic	Working pressure	bar	300(Max)
	Pump model	cc	Main : 112, 112/secondary : 60x2
	Flow rate	ℓ	930
Crawler base & Feed system	Traveling speed	km/hr	2.25
	Climbing capacity	°	20
	Ground pressure	kg/cm ²	0.90
	Winch capacity	ton	4.5
	Pull-back speed	m/min	29.26@1600rpm
	Pull-back capacity	ton	24.5
	Pull-down speed	m/min	17.83@1600rpm
	Pull-down capacity	ton	40.2
	Power head torque	kg.m	Max 4250
rpm		1st : 20, 2rd : 40	

*Standard Rod : Ø303mm x 7m x 5ea

Eco-Friendly KR5000

- Tier 4 Final Cummins engine installation.
- Turn-Table system for dust suppression.

ImProved Structural Stability KR5000

- Structural Stability by low position.
- Strong frame withstanding extreme working condition.
- Deep hole drilling carousel system(Automatic rods-exchanging).
- Tsubaki's super-chain & doubled-chain installed.
- Independent drive outrigger.
- Outrigger safety valve(Pilot check valve).

Field Requirements-Satisfied KR5000

- Multi-tasking rotary head.
- Verticality of drilling within 1/300.
- Running and redirection performance improved track.
- Multi-line level installed.
- 65mm diameter air passage(Various compressor available).
- Position controllable pilot driver cab.



CS RIG Series

New Model - Rokit 100 C-TR

Rokit 100 C-TR, a compact drilling rig, is designed for quick water supply in regions experiencing water shortages. It can be moved and installed very easily, and its reasonable price enhances global competitiveness as well.



Rokit 100 C-TR Specifications

Model		100 C-TR
Drilling Capacity		6" Hole x 100m
Feed System	Pull Up & Down	1,990kgf(19,500N)
	Fast Feed Speed	27m/min
	Feed Stroke	2m(76mm x 1.5m Rod)
Rotation	Hammer Drilling	Max. 65rpm x 1500Nm
	Rotary Drilling	Max. 120rpm x 1500Nm
Engine		31 HP (Vanguard Gasoline)
Hydraulic Pump		Double Gear Pump

- High Reliability & Easy Maintenance with Popular Engine
- High Work Efficiency with Integrated Swivel & Big Size Tank
- High Feed Force & Rotation Speed with Double Gear Hydraulic Pump
- Save Energy & Enhance Safety with Feed Speed Control Valve

New Model - Rokit 250 RD

Rokit 250 RD is highly useful drilling rig as a multi-purpose device. It has the "Automatic Rod Handler" for better work efficiency and the "Double Rotary Head" for drilling & casing simultaneously.



Rokit 250 RD Specifications

Model		250 RD
Lay Out	Width	2,200mm
	Length	8,800mm
	Height	2,300mm
	Weight	8,100kg
Engine	Spec	PU086 Diesel 118PS/ 1,400rpm
Hydraulic Pump	Spec	80cc + 80cc Piston Pump + 2 Gear Pump
Feed	Pull Up	9,500kgf
	Pull Down	5,600kgf
	Feed-Up Speed	21 m/min
	Feed-Down Speed	33 m/min
Rotary Head	RPM	0~60/ 0~120
	Torque	360kg*m
Casing Driver	RPM	Max. 31
	Torque	990kg*m
	Stroke	590mm
Auto Rod Handler	Spec	Φ 89 * 4m * 50ea
Option	Hammer Oil Injector	
	Electric Welder	

Automatic Rod Handler - High Work Efficiency
Double Rotary Head - Drilling & Casing Work Simultaneously

CS RIG Series



CS-2000 DHR

CS-2000 DHR drilling rig is a heavy duty drilling rig with simple design providing excellent performance at minimum maintenance for percussion drilling with down the hole hammer, rotary drilling with mud, reverse drilling, crown core drilling and reverse circulation drilling with optional drive head.

This rig adapts powerful engine & hydraulic pump, carries out various drilling task efficiently. With robust structure of mast, it grants very stable & strong power in pull back & pull up operation. Wide space on the frame with simple design provides easy maintenance. The rig would be transferred to 'transport mode' during driving position.

CS-2000 DHR Specifications

	Model	CS-2000
Dimension & Weight	Length(Mast Down)	15,100mm
	Height(Mast Down)	4,300mm
	Height(Mast Up)	15,600mm
	Width	2,500mm
	Weight	28,000kg
Torque		1,300/650kgf*m
Engine (or Customer Specified)		478kw/2,100rpm
Feed System	Pull Down	34,344kgf
	Pull Back	78,500kgf
	Feed Speed(Up)	20m/min
	Feed Speed(Down)	46m/min
Rotation	High	0~120 rpm
	Low	0~60 rpm
Winch	Capacity	3,000 kgf
Outrigger	Q'ty	4ea
	Operation Length	1,000mm
	Lifting Power	65,970 kgf/ea
Crawler Track	Ground Clearance	-
	Ttumbler Distance	-
	Shoes Width	-





CSI's 20 years of expertise reinforce our competitiveness in the field of drilling equipment. Our manufacturing capacity covers from a compact drilling rig to a large hydraulic drilling rig.



CS-100



CS-200



CS-350



CS-400



CS-600

Especially our diverse rig models are designed and manufactured by customizing process with the specific demands of users.

CS Drilling Rig Specifications

Model		CS-100	CS-200	CS-350	CS-400	CS-600
Dimension & Weight	Length(Mast Down)	4,950mm	5,100mm	5,400 mm	5,400 mm	8,000 mm
	Height(Mast Down)	2,260mm	2,400mm	2,450 mm	2,450 mm	2,600 mm
	Height(Mast Up)	5,500mm	5,700mm	6,000 mm	6,000 mm	8,500 mm
	Width	1,800mm	1,800mm	2,000 mm	2,000 mm	2,000 mm
	Weight	3,300kg	4,800kg	5,000 kg	7,500 kg	9,000 kg
Torque		200/100kgf*m	360/180kgf*m	500/250 kgf*m	500/250 kgf*m	500/250 kgf*m
Engine (or customer specified)		46kw/1,400rpm	77kw/1,400rpm	165 kw / 1,800 rpm	165 kw / 1,800 rpm	200 kw / 1,800 rpm
Feed system	Pull Down	1,970kgf	6,280kgf	8,808 kgf	8,808 kgf	13,816 kgf
	Pull Back	3,260kgf	11,304kgf	17,270 kgf	17,270 kgf	24,869 kgf
	Feed Speed(Up)	22 m/min	21 m/min	25 m/min	25 m/min	22.5 m/min
	Feed Speed(Down)	36 m/min	38 m/min	49 m/min	49 m/min	40.5 m/min
Rotation	High	0~120 rpm	0~120 rpm	0~120 rpm	0~120 rpm	0~120 rpm
	Low	0~60 rpm	0~60 rpm	0~60 rpm	0~60 rpm	0~60 rpm
Winch	Capacity	1,000 kgf	1,500 kgf	3,000 kgf	3,000 kgf	3,000 kgf
	Q'ty	4ea	4ea	4ea	4ea	4ea
Outrigger	Operation Length	1,050mm	1,200mm	1,400mm	1,400 mm	1,400 mm
	Lifting Power	6,500 kgf/ea	6,500 kgf/ea	8,080 kgf/ea	8,080 kgf/ea	13,360 kgf/ea
	Ground Clearance	340mm	350mm	363mm	363mm	363mm
Crawler track	Tumbler Distance	1,425mm	1,990mm	1,990mm	1,990mm	2,200 mm
	Shoes Width	250mm	400mm	380mm	380mm	450 mm

Various Models at Your Convenience

CS RIG Series



RCD Drilling M/C

CSI also provide Reverse Circulation Drilling machine which is used for large diameter, deep depth, bore piling in marine condition. And it is designed & manufactured depending on the diverse demands of users.

RCD Drilling M/C Specifications



Model		CPD 2000 Drilling Machine
Dimension		4,200mm * 5,350mm * 8,700mm
Weight		28,000kg
Rotation	Speed	0~10rpm(max.22rpm)
	Torque	149.4kn*m(250bar)
Thrust Force	Pull Down	61.2ton
	Pull Up	100.5ton
Feed Stroke		3.65m
Power Pack	Power	230kw/1,400rpm
	Engine	doosan pu126ti
	Hyd` Pump	140 * 2 / 63 * 1
	Max. Pressure	350bar(operating 250bar)
System		hold back system
		drilling speed control system



Crawler

Changeable track as necessary : Rubber (Top) & Steel (Bottom)



Swingable Operator Platform

Crawler Specifications

Model	2Ton - Crawler	3Ton - Crawler	4Ton - Crawler
Width	1.35m	1.35m	1.8m
Height	0.6m	0.6m	0.45m
Length	2.3m	2.3m	1.9m
Carrying Capacity	2 Ton	3 Ton	4 Ton
Power Unit	9~10Hp Diesel Engine	9~10Hp Diesel Engine	13HP Diesel Engine
Track Type	2 x Rubber Type	2 x Rubber Type	2 x Rubber Type
Track Size	0.35(W) x 1.5m(H)	0.45(W) x 1.5m(H)	0.25(W) x 1.5m(H)

Roof Piling M/C



Soil Nailing M/C



Roof Piling M/C Specifications

Model	HD2350
Torque	745kgf*m
Width	2,600mm (outrigger open: 3,600~4,000mm)
Machine speed	3.2km/hr
Mounting CAPA.	35deg.
Height	3,800mm
Weight	19,500kg
Engine	75kw / 2,200rpm
Leader rotation	250 deg.
Working height, Max extended leader	7,050mm
Pipe holder	Ø 114mm basic
Clamp power	30ton
Option	electric power system

Soil Nailing M/C Specifications

Model		Soil Nailing M/C
Dimension		3,162mm * 580mm * 460mm
Weight		155kg
Rotation	Hydraulic motor	MT500
	Max Torque	1,200Nm (160bar)
Feed	Hydraulic motor	TG0335
	Feed force	1ton (140bar)
	Max Feed force	1.6ton (210bar)
Feed Stroke		2.0m
Power Pack	Dimension	1,000mm * 1,700mm * 1,075mm
	Weight	400kg
	Power Diesel engine	34PS/1500rpm 42PS/1800rpm
	Hydraulic Pump	Gear pump / 20cc + 20cc Max pressure: 240bar

CS Hammer Series



CS Power Hammer

CS Power Hammer is optimized to meet the demand of quick work in the processes of anchoring, quarry job, constructions and water well drilling. And, these days it is also used in geothermal development field widely.

CS-50 RC



CS-530



CS-800

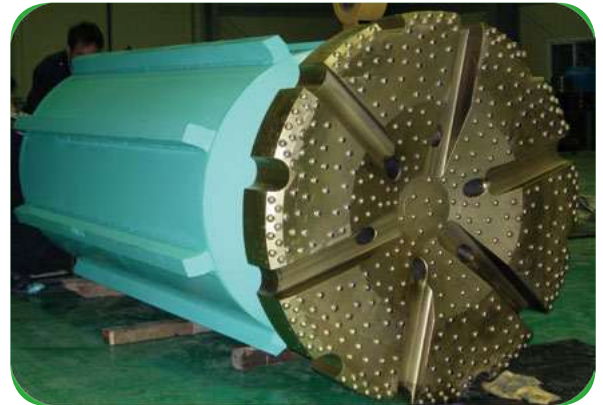

CS Power Hammer Specifications

Model	CS-20	CS-30	CS-40	CS-40S (low)	CS-50	CS-60	CS-60S (low)	CS-80	CS-100	CS-112	CS-320	CS-380	CS-410	CS-530	CS-640	CS-800
(Backhead) Connection	RD50 - 6TPI PIN	API 2-3/8" REG PIN	API 2-3/8" REG PIN	API 2-3/8" REG PIN	API 3-1/2" REG PIN	API 3-1/2" REG PIN	API 3-1/2" REG PIN	API 4-1/2" REG PIN	API 6-5/8" REG PIN	API 6-5/8" REG PIN	API 7-5/8" REG	API 8-5/8" REG PIN	API 8-5/8" REG PIN	Hex Joint	Hex Joint	Hex Joint
Chuck Connection Configuration	BR2	DHD 3.5	DHD 340, SD4	DHD 340, SD4	DHD 350, SD5	DHD 360, SD6	DHD 360, SD6	DHD 380, SD8	N100 SD10	DHD112 A100 -15 SD12	Korean Own Model					
Available Bit Size/mm	70~80	85~127	105~130	105~130	125~150	149~225	149~225	191~270	251~311	301~445	380~480	432~559	457~650	675~800	775~975	975~1,175
Length/mm (Without Bit)	820	IR945 MS 978	IR1,040 MS 1,088	IR1,020 MS 1,068	IR1,162 MS 1,162	IR1,368 MS 1,383	IR1,184 MS 1,203	IR1,420 MS 1,390	IR1,545 MS 1,527	IR1,890 MS 1,895	1,961	1,850	2,053	2,489	2,399	2,516
Outside Diameter/mm	62	78	97	97	117	138	138	180	226	272	320	353	410	530	640	800
Cylinder Bore/mm	-	58	75	75	91	108	108	148	170	216	266	260	310	410	445	508
Piston Stroke/mm	100	100	100	100	100	100	100	100	100	100	110	125	150	150	150	127
Net Weight/Kg (Without Bit)	12	28	40	38	65	108	95	185	335	620	920	1,180	1,510	2,764	3,839	6,435
Gross Weight/Kg (W/Wooden Box)	15	35	46	44	69	115	103	200	355	640	945	1,205	1,540	2,794	3,869	6,465

DHD/QL/SD/NUMA



2"~40" Full Size Line Up

Unique Design from Ingersoll-Rand DHD & Sandvik-Smith Proto Type
 Maximum Performance & Minimum Maintenance
 Various Models for Different Applications

High Quality & Reasonable Price

CS Power Hammer Air Consumptions (at Sea Level)

cfm (m³/min)

Model	CS-20	CS-30	CS-40	CS-40S (low)	CS-50	CS-60	CS-60S (low)	CS-80	CS-100	CS-112	CS-320	CS-380	CS-410	CS-530	CS-640	CS-800
100PSI (6.8BAR)	70 (2.8)	170 (4.8)	190 (5.4)	195 (5.5)	200 (5.7)	270 (7.6)	300 (8.5)	400 (11.3)	500 (14.1)	600 (16.9)	800 (22.7)	950 (26.9)	1,220 (34.5)	1,450 (40.6)	1,850 (52.4)	2,300 (65.1)
150PSI (10.3BAR)	120 (3.5)	245 (6.9)	265 (7.5)	278 (7.8)	285 (8.1)	385 (10.8)	450 (12.7)	585 (16.5)	750 (21.2)	880 (24.8)	1,100 (31.1)	1,280 (36.2)	1,430 (40.5)	2,150 (60.9)	2,800 (79.3)	3,500 (99.1)
200PSI (13.8BAR)	170 (4.8)	350 (9.8)	365.5 (10.3)	383 (10.3)	400 (11.3)	545 (15.3)	600 (17)	840 (25.2)	1,050 (29.7)	1,100 (31.1)	1,700 (48.1)	1,850 (52.4)	2,120 (60)	2,900 (82.1)	3,700 (104.8)	5,300 (150.1)
250PSI (17.2BAR)	220 (6.5)	485 (13.7)	485 (13.7)	509 (14.1)	520 (14.7)	715 (20.2)	795 (22.5)	890 (25.2)	1,200 (34)	1,450 (41.1)	2,040 (57.8)	2,320 (65.7)	3,000 (85)	3,930 (111.3)	4,600 (130.3)	7,250 (205.3)
300PSI (20.7BAR)	270 (7.6)	582 (16.5)	600 (16.9)	630 (17.5)	645 (18.3)	865 (24.5)	940 (26.7)	1,085 (30.7)	1,600 (45.3)	1,880 (53.2)	2,448 (69.3)	2,668 (75.5)	4,070 (114)	4,830 (135.2)	5,500 (154)	9,200 (257.6)
350PSI (24.1BAR)	320 (8.8)	669 (19)	700 (19.8)	735 (20.5)	770 (21.7)	924 (26.2)	1,030 (29.3)	1,520 (43)	1,800 (51)	2,068 (58.6)	2,693 (76.3)	3,068 (86.9)	4,760 (133)	5,780 (161.8)	6,400 (179.2)	11,000 (308)

CS Hammer Series



CS Speedrill(Neodrill) Hammer

CS Speedrill(Neodrill) is valveless model which is free of foot valve broken during the operation. And piston stroke is increased than standard model, which means striking power is stronger than before.

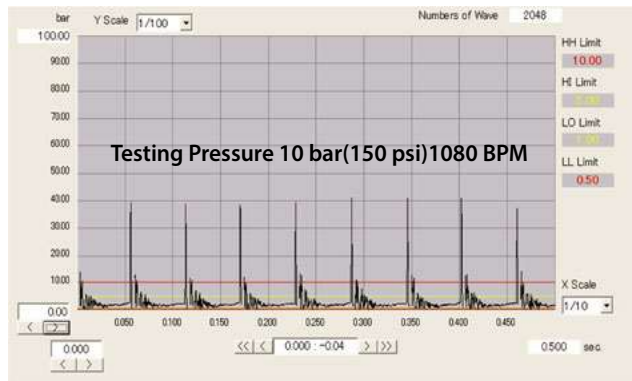
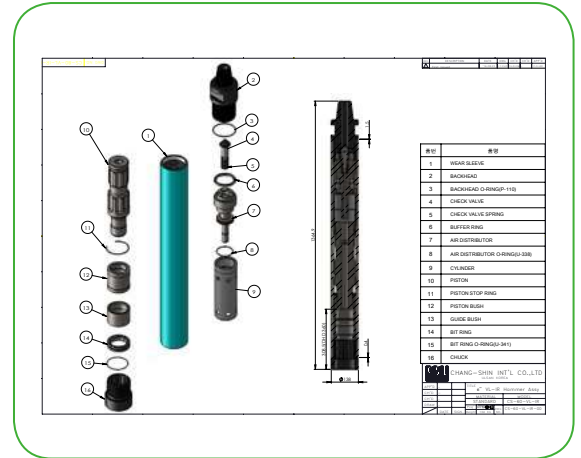

Increase 9% Hitting Power
 Increase 12.5% Frequency
 Increase 18% Penetration Speed

*Increase Performance
 & Shock Absorbing*



CS Speedrill(Neodrill) Specifications

Model	CS Speedrill 60	CS Speedrill 80	CS Speedrill 100
(Backhead) Connection	API 3-1/2 Reg Pin	API 4-1/2 Reg Pin	API 6-5/8 Reg Pin
Chuck Connection Configuration	DHD 360 SD 6	DHD 380 SD 8	SD 10
Available Bit Size/mm	149 ~ 225	191 ~ 270	251 ~ 340
Length/mm (Without Bit)	1364.9(DHD) 1379.5(SD)	1413.9(DHD) 1387.5(SD)	1528(SD)
Outside Diameter/mm	138	180	225
Piston Stroke/mm	90	90	90
Net Weight/Kg (Without Bit)	104	185	330
Gross Weight/Kg (W/Wooden Box)	114	195	345
Air Consumption (250psi/17.2bar)	700	870	1180
(at Sea Level CFM)			

CS Auger Hammer

CSI auger hammer is special in that it combines the strong points of pneumatic hammer and auger bit in an effective way. It will be the best choice to bore holes in complex rock strata of weathered, sedimentary, soft and hard rock.



CS Coming Product; Mud DTH Hammer

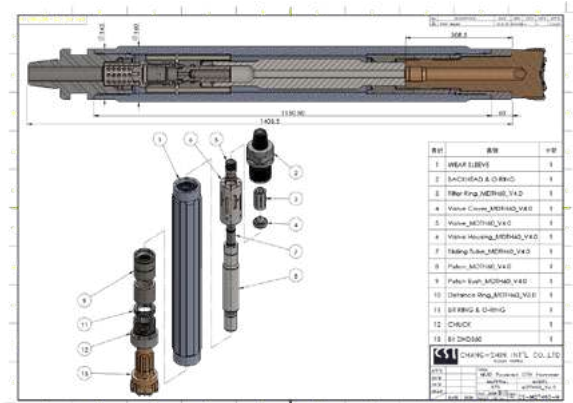

Innovation & Distinction

CS Mud Hammer is operated by mud, drilling fluid. It has each advantage of Rotary drilling that can be secure drilling stability, and Percussion that can be accomplished outstanding drilling speed.

CS BIT Series



CS Button Bits

CSI has accumulated expertise in designing and producing all kinds of button bits. Especially we specialize in producing tungsten carbide bits for better cutting power and faster penetration speed.

2"~47"

Full Size Line Up

DHD/QL/SD/MISSION/NUMA



High Quality & Reasonable Price



CS Button Bits Specifications

Hammer Size	Bit Size	Bit Weight(Lbs)/(kg)	Face Design
CS-20 (BR2)	76 mm	6.6Lbs / 3Kg	Flat, Concave, Convex
	80 mm	6.6Lbs / 3Kg	
CS-30(SD3/DHD3.5)	90 mm	8.8Lbs / 4kg	
	100 mm	9.3Lbs / 4.2kg	
CS-40(SD4/DHD340A)	4"	18Lbs / 8.2Kg	
	4-1 / 2"	22Lbs / 10kg	
	5"	22.9Lbs / 10.4kg	
CS-50(SD5/DHD350R)	5"	32Lbs / 14.5kg	
	5-1/2"	35.3Lbs / 16Kg	
CS-60(SD6/DHD360)	6"	57.27Lbs / 26Kg	
	6-1/2"	65.78Lbs / 29.9kg	
	8"	80Lbs / 36.3kg	
	10"	125Lbs / 57kg	
CS-80(SD8/DHD380)	7-7/8"	91Lbs / 41.3kg	
	8"	92.84Lbs / 42.2kg	
	10"	154.66Lbs / 70.3kg	
	12"	207.46Lbs / 94.3kg	
CS-100(SD10/N100)	10"	237.6Lbs / 108kg	
	12"	275Lbs / 125kg	
CS-112 (A100/SD12/DHD112)	12"	384Lbs / 174kg	
	15"	478Lbs / 217kg	
	17-1/2"	517Lbs / 259kg	
CS-320(Own Model)	15"	451Lbs / 205kg	
CS-380(Own Model)	17-1/2"	781Lbs/355kg	
	17"	640Lbs / 290kg	
	19"	773Lbs / 350kg	
CS-410(Own Model)	21"	909Lbs / 412kg	
	22"	1,345Lbs / 610Kg	
	23"	1,411Lbs / 640Kg	
CS-530(Own Model)	25"	1,543Lbs / 700Kg	
	25"	2,425Lbs / 1,100kg	
	27"	2,601Lbs / 1,180kg	
CS-640(Own Model)	30"	2,976Lbs / 1,350kg	
	27"	3,902Lbs / 1,770kg	
	30"	4,696Lbs / 2,130kg	
CS-800(Own Model)	32"	5,159Lbs / 2,340kg	
	34"	5,093Lbs / 2,310kg	
	36"	5,401Lbs / 2,450kg	
	40"	5,732Lbs / 2,600kg	

ROCWing Bits

ROCWING 240 is a concentric overburden bit for a hard formation rock bed. Because of enclosed rocwing bits, it shows the most efficient and powerful performance in ground drilling jobs.

Part Name

No.	Part Name	EA	Part No.
1	Guide Device	1	TBA
2	Pilot Bit	1	TBA
3	Wing Bit	4	TBA
4	Socket Set Screw	4	TBA
5	Stop Pin	8	TBA

Specifications

Item	Part No.
Major Body Diameter	240 mm
Length	737 mm
System Open	292 mm
Casing Size O/D	270/254 mm
Total Weight	133 kg

ROCWING

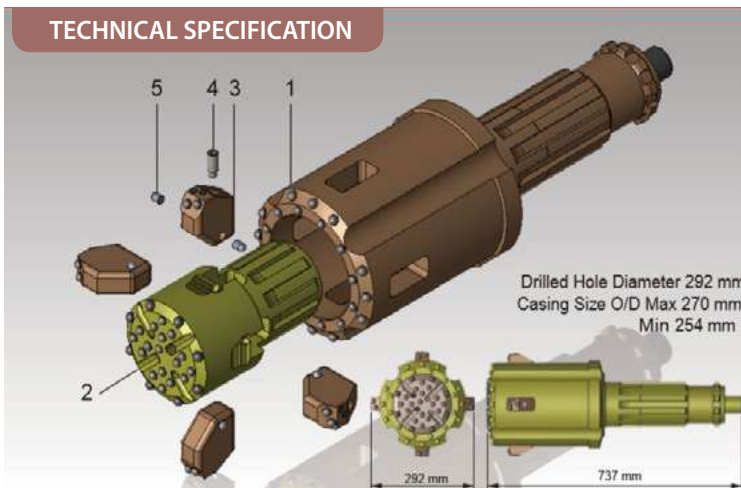

CS BIT Series



Overburden Bits

CSI is supplying diverse overburden bits such as "Eccentric Type", Wing Type, "Symetric Type" and "Hemi Type". They all show great cutting power and fast penetration speed on overburden drilling.

Symetric Type



Wing Type



Hemi Type



Eccentric Type



Various Bits

Hole Opener Bit



Drag Bit



HDD Bit



Concrete Bit

Auger Bit



Promotional Items

Tricone Bits



PDC Bit



Claw Bit

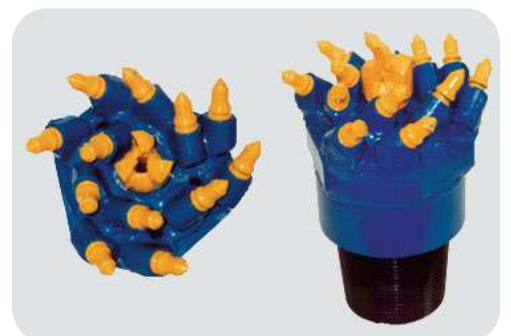

CS Auxiliary Equip



Features

- Friction Welded for Connection API
- Specification for Raw Materials
- International Standard for Various Tool Joints

Drill Rods

CSI can also supply various rods for all kind of DTH drilling works. CSI drill rods fulfill their function of transmitting rotation power from drilling machine to the bit, and supplying high pressure to air and water. They can be connected to tens or thousands of meters in length.



Screw Rods



Leader Assembly



Shock Absorbers & Swivel

Along with our main products, we also develop and manufacture a variety of auxiliary equipment. Especially we are providing optimized auxiliary equipment, such as shock absorbers, rotary heads and mud pumps to extend the service life of rigs and ensure more convenient and safer work.

Shock Absorber Specifications

Size	Outside Dia. /mm	Length /mm
3"	77 mm	496 mm
4"	97 mm	496 mm
5"	117 mm	580 mm
6"	138 mm	580 mm
8"	180 mm	656 mm
10"	225 mm	1,017 mm
12"	270 mm	1,017 mm



Rotary Head



Breakout Bench

CSI Breakout Bench is a cost effective way of recovering bits and bottom subs from bent or broken drill rods. Our Breakout Bench is a great help when servicing, maintaining and repairing a DTH-hammer.



CSI
www.okcsi.com



CHANG SHIN INT'L CO., LTD

32, Cheoyongsaneop 3-gil, Onsan-eup, Ulju-gun, Ulsan, Korea

Phone +82-52-239-3878 E-mail csi@okcsi.com

Fax +82-52-237-0358 Http www.okcsi.com

2020.01

